

# ULB03

## UNDERWATER LIGHT

**HEAVY DUTY  
STAINLESS  
STEEL**

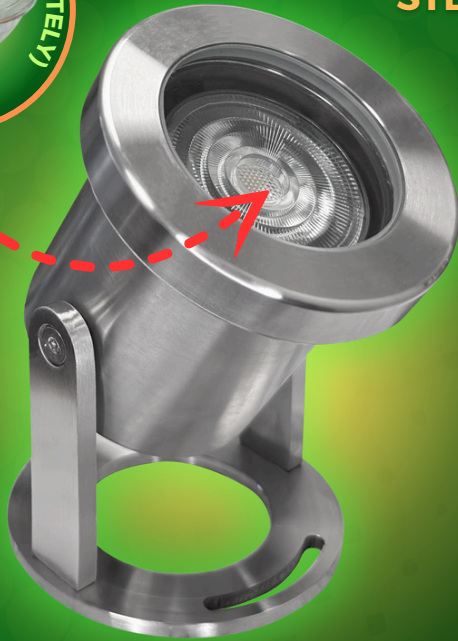

### SPEC SHEET

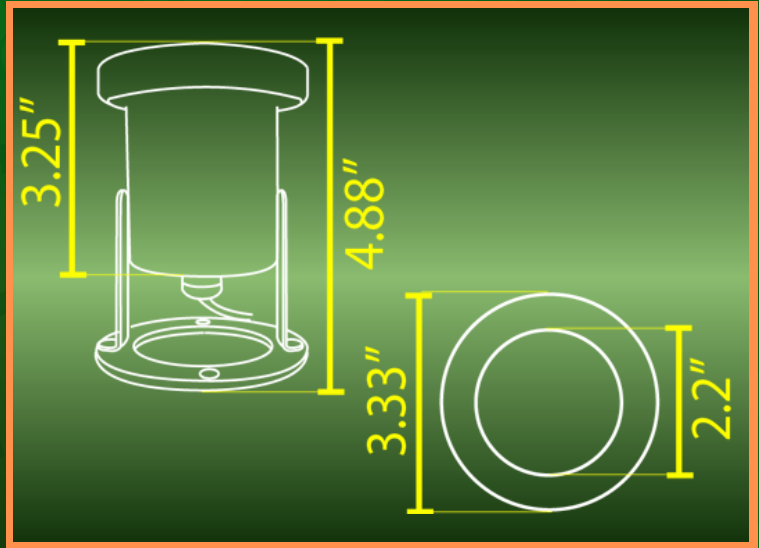

**2700K 3000K 4000K**



**5000K RGBW**

### FINISH:



THE ULB03 STAINLESS STEEL UNDERWATER LIGHT IS A PROFESSIONAL-GRADE LOW-VOLTAGE FIXTURE DESIGNED FOR UNDERWATER APPLICATIONS THAT DEMAND DURABILITY, CLEAN STYLING, AND DEPENDABLE LONG-TERM PERFORMANCE. BUILT WITH A HEAVY-DUTY 304 STAINLESS STEEL BODY AND FINISHED IN STAINLESS STEEL, THIS FIXTURE IS MADE TO PERFORM IN CHALLENGING WET-LOCATION ENVIRONMENTS WHILE MAINTAINING A REFINED, MODERN APPEARANCE. ITS SOLID CONSTRUCTION MAKES IT A STRONG CHOICE FOR CUSTOMERS LOOKING FOR A RELIABLE UNDERWATER LIGHTING SOLUTION FOR DECORATIVE WATER FEATURES AND LANDSCAPE INSTALLATIONS.

DESIGNED TO USE AN MR16 LED 12V BULB SOLD SEPARATELY, THE ULB03 GIVES INSTALLERS THE FLEXIBILITY TO CHOOSE THE MOST SUITABLE LAMP OUTPUT AND COLOR TEMPERATURE FOR THE PROJECT. THE PRODUCT PAGE ALSO REFERENCES COMPATIBLE MR16 LED BULB OPTIONS IN MULTIPLE WATTAGES AND COLOR TEMPERATURES, MAKING THIS FIXTURE ADAPTABLE FOR DIFFERENT VISUAL EFFECTS, FROM WARMER DECORATIVE ILLUMINATION TO BRIGHTER, CLEANER WHITE LIGHT.

MASTER BOX

**12  
PIECES**

INCLUDED:

**16  
FEET  
WIRE**

WATERPROOF  
RATING:

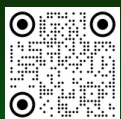

YOUTUBE VIDEO  
INSTALLATION GUIDE



WEBSITE



CATALOG

**ABBA**  
LIGHTING USA  
*12V Landscape Light Specialist*



(800) 360-2960



ABBALightingUSA@gmail.com



7701 Alabama Ave, Canoga Park, CA 91304