

# ULB01

## UNDERWATER LIGHT



**HEAVY DUTY  
CAST BRASS**



### SPEC SHEET

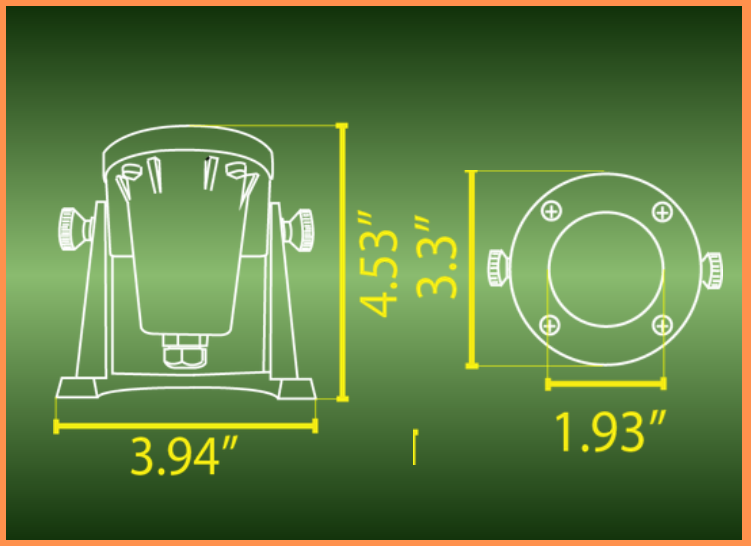

### FINISH:



THE ULB01 BRASS UNDERWATER LIGHT IS A DURABLE LOW-VOLTAGE FIXTURE DESIGNED FOR WATER-FEATURE LIGHTING APPLICATIONS WHERE STRENGTH, RELIABILITY, AND A PREMIUM APPEARANCE ARE ESSENTIAL. BUILT WITH A HEAVY-DUTY CAST BRASS BODY AND FINISHED IN NATURAL BRASS, THIS MODEL OFFERS A MORE SUBSTANTIAL AND REFINED ALTERNATIVE TO ORDINARY UNDERWATER FIXTURES. ITS SOLID BRASS CONSTRUCTION GIVES IT THE DURABILITY NEEDED FOR DEMANDING OUTDOOR ENVIRONMENTS WHILE ALSO PROVIDING THE CLASSIC, PROFESSIONAL LOOK THAT WORKS BEAUTIFULLY IN DECORATIVE LANDSCAPE AND WATER INSTALLATIONS.

DESIGNED TO OPERATE WITH AN MR16 LED 12V BULB SOLD SEPARATELY, THE ULB01 GIVES INSTALLERS THE FREEDOM TO CHOOSE THE LAMP THAT BEST FITS THE PROJECT'S DESIRED BRIGHTNESS AND COLOR TONE. THE PRODUCT PAGE REFERENCES SEVERAL COMPATIBLE MR16 LED BULB OPTIONS, INCLUDING MULTIPLE WATTAGES AND COLOR TEMPERATURES, MAKING THIS FIXTURE FLEXIBLE ENOUGH FOR A RANGE OF LIGHTING EFFECTS. WHETHER THE GOAL IS A WARMER AND MORE INVITING GLOW OR A CLEANER, BRIGHTER ACCENT, THIS HOUSING CAN BE ADAPTED TO SUIT DIFFERENT POND AND FOUNTAIN DESIGNS.

MASTER BOX

**12  
PIECES**

INCLUDED:

**16  
FEET  
WIRE**

WATERPROOF RATING:

**IP68**



YOUTUBE VIDEO  
INSTALLATION GUIDE



WEBSITE



CATALOG

**ABBA**  
LIGHTING USA  
*12V Landscape Light Specialist*



(800) 360-2960



ABBALightingUSA@gmail.com



7701 Alabama Ave, Canoga Park, CA 91304