

UNSO5

WELL LIGHT



HEAVY DUTY
STAINLESS STEEL



SPEC SHEET

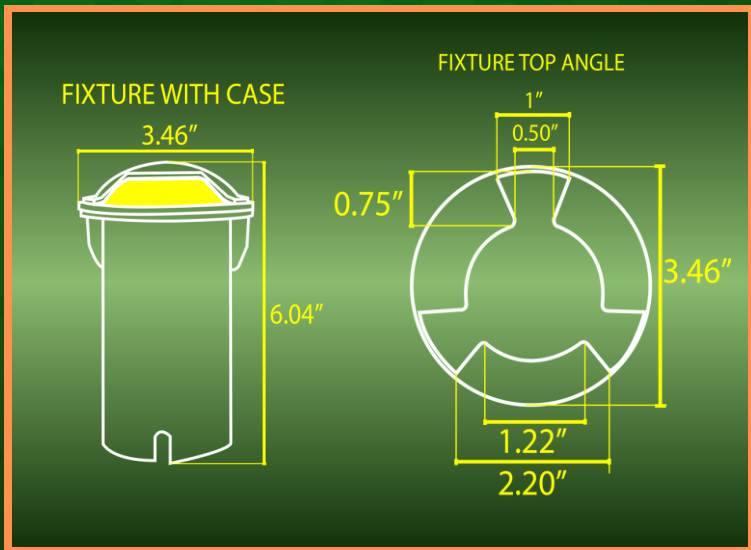

FINISH:



MR16 SOLD SEPARATELY

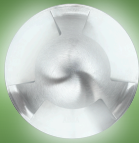
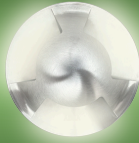
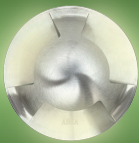
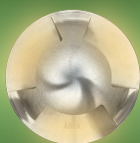

2700K 3000K 4000K 5000K

FEATURE

FIXED
INNER
BRACKET

INCLUDED:

18/2
DIRECT BURY
LANDSCAPE
LIGHTING WIRE

WATERPROOF RATING:



ELEGANT YET HIGHLY FUNCTIONAL, THE UNSO4 OFFERS DURABLE CONSTRUCTION, IP65 PROTECTION, AND BI-DIRECTIONAL UPLIGHT IN A REFINED STAINLESS-STEEL FIXTURE. ITS COMPATIBILITY WITH MR16 LED BULBS GIVES DESIGNERS CONTROL OVER BRIGHTNESS, TEMPERATURE, AND BEAM STYLE—WHILE ITS RECESSED FORM ENSURES A CLEAN, BUILT-IN AESTHETIC THAT ENHANCES RATHER THAN INTERRUPTS YOUR LANDSCAPE DESIGN.

THE UNSO5 COMBINES SLEEK AESTHETICS WITH BROAD-BEAM FUNCTIONALITY, ENGINEERED FOR SEAMLESS INTEGRATION IN UPSCALE OUTDOOR ENVIRONMENTS. ITS TRI-DIRECTIONAL OUTPUT DELIVERS EXPANSIVE, EVEN ILLUMINATION WHILE ITS STAINLESS-STEEL HOUSING ENSURES RESILIENT PERFORMANCE. CHOOSE THE UNSO5 FOR LIGHTING SCHEMES THAT DEMAND COVERAGE, ELEGANCE, AND LONGEVITY.



YOUTUBE VIDEO
INSTALLATION GUIDE



WEBSITE



CATALOG

ABBA

LIGHTING USA

12V Landscape Light Specialist



(800) 360-2960



ABBALightingUSA@gmail.com



7701 Alabama Ave, Canoga Park, CA 91304