

UNSO1

WELL LIGHT



HEAVY DUTY
STAINLESS STEEL



SPEC SHEET

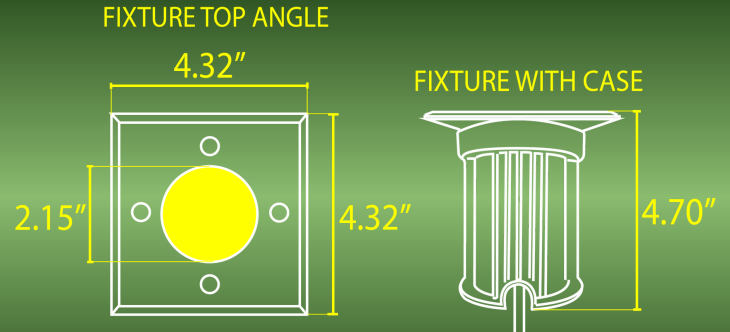

Black

FINISH:



Stainless Steel

MR16 SOLD SEPARATELY



2700K 3000K 4000K 5000K

FEATURE

FIXED
INNER
BRACKET

CERTIFICATE:



WATERPROOF
RATING:



THE UNSO1 SQUARE WELL LIGHT BY ABBA LIGHTING USA IS A ROBUST, ARCHITECTURAL-GRADE IN-GROUND LUMINAIRE DESIGNED TO INTEGRATE SEAMLESSLY WITH MODERN LANDSCAPES. ITS CLEAN, FLUSH-MOUNTED SQUARE HOUSING AND PREMIUM MATERIALS PROVIDE SOPHISTICATED UPLIGHTING FOR TREES, WALLS, PILLARS, OR ENTRYWAYS—WHILE MAINTAINING A SLEEK, UNOBTRUSIVE PRESENCE.

THE UNSO1 OFFERS A SOPHISTICATED, HIGH-PERFORMANCE LIGHTING SOLUTION TAILORED FOR DISCERNING DESIGNERS, CONTRACTORS, AND HOMEOWNERS. ITS HEAVY-GAUGE STAINLESS STEEL HOUSING ENSURES ENDURING QUALITY, WHILE ITS FLUSH, GEOMETRIC FORM OFFERS ELEGANT LIGHTING WITHOUT VISUAL CLUTTER. MR16 LAMP FLEXIBILITY ALLOWS ARTISTIC LIGHT CHOICE—MAKING IT A REFINED ADDITION TO UPSCALE LANDSCAPES OR COMMERCIAL OUTDOOR PROJECTS.



YOUTUBE VIDEO
INSTALLATION GUIDE



WEBSITE



CATALOG

ABBA

LIGHTING USA

12V Landscape Light Specialist



(800) 360-2960



ABBALightingUSA@gmail.com



7701 Alabama Ave, Canoga Park, CA 91304